



ZANOTTI Spa
 Via M.L. King, 30
 46020 - Pegognaga (MN) - ITALY
 Tel. +39 0376 5551
 Fax +39 0376 536554
 info@zanotti.com

Technical specifications

Version 2.2

Model: **MGM212EB11XA** Class: **GM**

Technical data

Characteristics	M.U.	Value
Working temperature	°C	+10 ÷ -5
Starting mode		Direct
Voltage	Volt-Ph-Hz	400/3N~/50
Rated input	kW*	1.70
Rated input	Amp*	4.60
Peak current	Amp	27.0
Max current	Amp	9.3
Refrigerant		R134a
	GWP	1430
Defrost		Hot gas
Mass	Kg	80

Compressor

Type		Hermetic
Nominal power	kW	1.7

Condenser

Air flow	m³/h	1200
----------	------	------

Evaporator

Air flow	m³/h	1200
Air throw	m**	4

PED Category		0
--------------	--	---



Power data

Tc °C	Ta °C	P watt	P Kcal/h	V100 m³	V80 m³	V60 m³
	20	3314	2850	39	35	32
	25	3150	2709	36	33	30
10	30	2981	2564	33	30	27
	35	2804	2411	31	28	26
	40	2617	2251	28	25	23
	45	2418	2079	25	23	21
	20	2772	2384	30	27	25
	25	2575	2214	27	25	22
5	30	2439	2098	25	23	21
	35	2334	2007	24	22	20
	40	2225	1914	22	20	18
	45	2081	1790	20	18	17
	20	2339	2012	24	22	20
	25	2165	1862	21	19	17
0	30	2034	1749	19	17	16
	35	1927	1657	17	15	14
	40	1822	1567	17	15	14
	45	1700	1462	16	15	13
	20	1956	1682	18	16	15
	25	1739	1496	16	15	13
-5	30	1615	1389	15	14	12
	35	1539	1324	14	13	12
	40	1463	1258	13	12	11
	45	1344	1156	11	10	9.1

Calculation of the refrigerating power and volume

Ta
 °C

Tc
 °C

PF
 Watt

Kcal/h

V100
 m³

V80
 m³

V60
 m³

* When normally running: 0 ÷ +30°C

** Use air throw as a base. Air throw is affected by many factors such as height of room, product storage, location of evaporator, etc.

Tc: Coldroom temp. - Ta: External temp.

P: Refrigerant capacity - V: Recommended cold-room volume

L'immagine è datata e potrebbe presentare alcune differenze rispetto all'unità attuale. La aggiorneremo il prima possibile.
The picture is old and it could have some differences from the current unit. We will update it as soon as possible.

Dimensioni - Dimensions - Dimensions
Abmessungen - Dimensiones

GM2

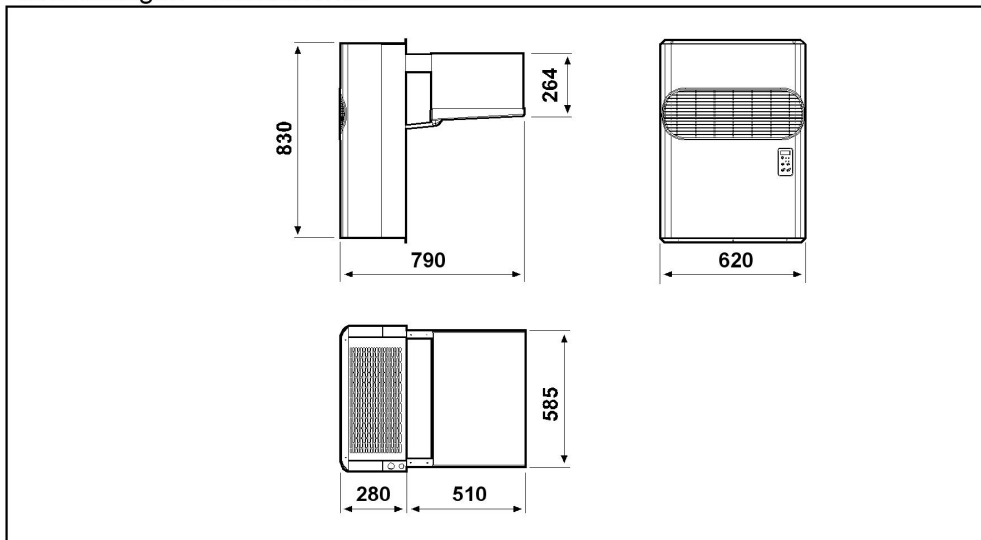

Schema di montaggio - Mounting scheme - Schema de montage
Montageschema - Esquema de montaje

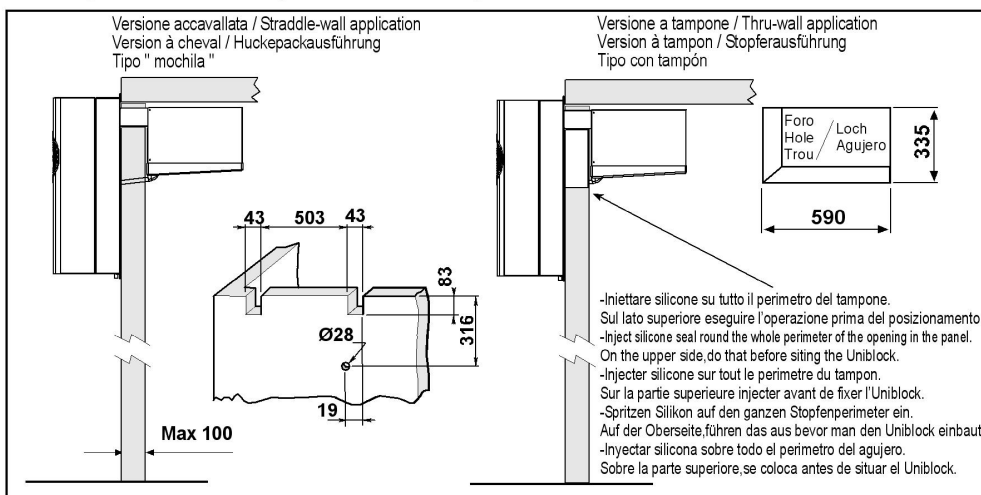

- * Raccomandazioni in sede di installazione e per il controllo fornite sul manuale di installazione
- * To be advised at time of order for factory installation and operating instructions
- * Recommendations au moments d'installations et pour le contrôle fournis sur le manuel d'installation
- * Empfehlungen für die Installationsphase und zur Kontrolle, die im Handbuch zur Installation enthalten sind
- * Por cuanto respecta a recomendaciones de instalación y control ver manual de instalación

Massa e misure imballi - Packing mass and dimensions - Masse et dimensions emballages
Verpackungsmasse und-abmessungen - Masa y medidas del embalaje

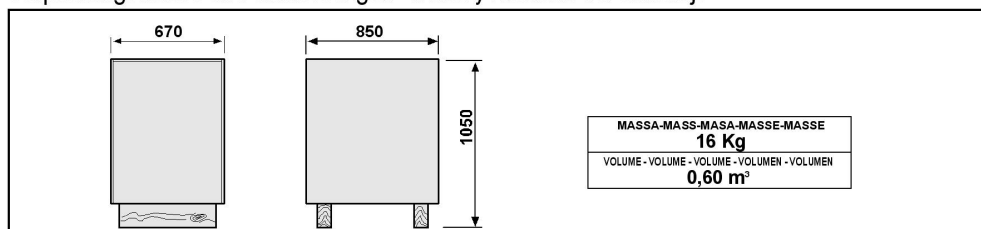

ZANOTTI S.p.A.